

UniSim® Heat Exchangers

User Guide

Honeywell

Copyright

March 2008 R380 Release

The information in this help file is subject to change over time. Honeywell may make changes to the requirements described. Future revisions will incorporate changes, including corrections of typographical errors and technical inaccuracies.

For further information please contact

Honeywell
300-250 York Street
London, Ontario
N6A 6K2
Telephone: (519) 679-6570
Facsimile: (519) 679-3977

Copyright Honeywell 2008. All rights reserved.

Prepared in Canada.

Table of Contents

1	Introducing UniSim® Heat Exchanger Software ...	1-1
1.1	The Product Family.....	1-1
1.2	UniSim® Heat Exchanger Programs.....	1-2
1.3	UniSim® STE	1-3
1.4	UniSim® CFE	1-5
1.5	UniSim® PFE.....	1-7
1.6	UniSim® FPH	1-8
1.7	UniSim® PHE	1-10
1.8	UniSim® FWH	1-11
1.9	UniSim® PPL.....	1-13
1.10	Documentation for UniSim® Heat Exchanger Programs	1-14
1.11	Technical Support	1-15

1 Introducing UniSim® Heat Exchanger Software

1.1 The Product Family

The Honeywell UniSim Heat Exchanger Suite is a set of validated programs designed for use by the process design community for the thermal design and simulation of heat exchange equipment. They offer a high level of confidence in predicting heat transfer and fluid flow characteristics in single and two-phase flow, including considerations such as flow stability and maldistribution, and provide comprehensive fluid property predictions to support these.

The software is easy to use, with a comprehensive and flexible graphical user interface. The programs are accompanied by detailed documentation and online help. Further help and support are available through the Honeywell global support team.

In the online help for each program you may find references to Design Reports, Research Reports and Handbook Sheets. Please contact Honeywell via email (unisim.support@honeywell.com) for information on access to these documents.

The programs can readily exchange information with Honeywell's UniSim Design process simulator and other third-party and in-house software to provide an integrated design office solution.

1.2 UniSim® Heat Exchanger Programs

UniSim Heat Exchangers have five main programs, each for a different type of equipment.

Name	Model	Model
UniSim® Shell and Tube Exchanger Modeler	UniSim® STE	Shell and tube heat exchangers
UniSim® Cross Flow Exchanger Modeler	UniSim® CFE	Air coolers and other crossflow exchangers
UniSim® Plate-Fin Exchanger Modeler	UniSim® PFE	Plate-fin heat exchangers
UniSim® Fired Process Heater Modeler	UniSim® FPH	Furnaces and fired heaters
UniSim® Plate Heat Exchanger Modeler	UniSim® PHE	Plate heat exchangers
UniSim® Feedwater Heat Exchanger Modeler	UniSim® FWH	Feedwater heat exchanger
UniSim® Process Pipeline Heat Exchanger Modeler	UniSim® PPL	Process Pipeline heat exchanger

1.2.1 Functionality

The main UniSim Heat Exchanger programs all offer some or all of the following basic functionality:

- DESIGN - for cost or area optimised thermal design to your specified process conditions and geometrical constraints;
- CHECKING - to check whether a given exchanger will achieve the required duty for your specified inlet and outlet conditions, giving the ratio of the actual to required surface area;
- SIMULATION - to calculate the outlet conditions and performance of a given exchanger from your specified inlet conditions.
- THERMOSYPHON - to calculate the performance of a vertical or horizontal thermosyphon reboiler, the circulation rate, and the pipework pressure drops.

1.2.2 Physical Properties

UniSim Heat Exchanger programs contain the **UniSim® Thermo** properties databank, with 1000+ components, and a choice of methods for vapour-liquid equilibrium and fluid properties calculations. Properties data can be set up and reviewed prior to the main flow and heat exchange calculations. Subsidiary properties facilities available include the 40-component **Internal Physical Property Databank**

(NEL40), which can be used in conjunction with any component for which you provide data, and options to store and recover stream properties in your own databank.

UniSim Heat Exchanger programs can import process and properties data from all the main process simulators. You can also set up a facility whereby you can access and generate data from your company's own properties data software, while running an UniSim Heat Exchanger program.

1.3 UniSim® STE

Shell and Tube Heat Exchangers

The UniSim® STE program gives you powerful capabilities for a wide range of exchanger applications, including condensers, condensers with desuperheating and cooling, multicomponent partial condensers, reboilers, falling film evaporators and multishell, multiphase feed-effluent trains.

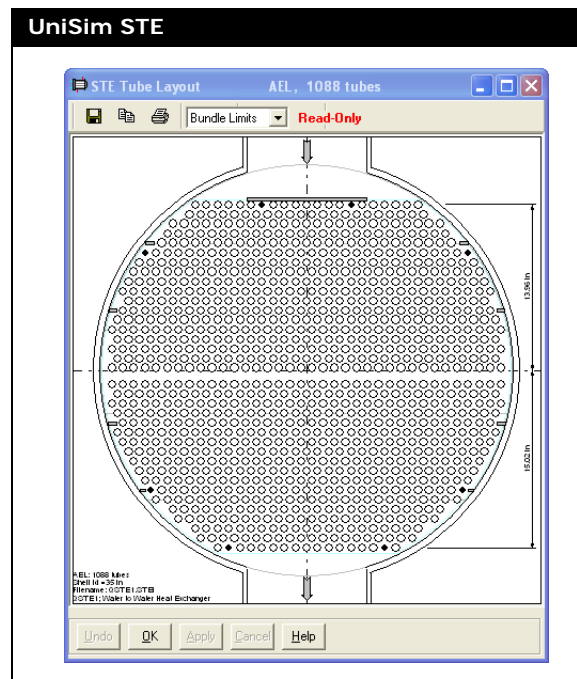

Functionality

The basic UniSim® STE calculations are

- **DESIGN**
- **CHECKING**
- **SIMULATION**
- **THERMOSYPHONS**

The Simulation option in UniSim® STE is of extended form permitting either inlet conditions, or outlet conditions or flowrate to be calculated (for either stream) given the other two parameters.

Technical Summary

- Multishell capability with up to 12 shells in series and any number in parallel.
- TEMA, E, F, G, H, I, J, K and X shells.
- Double pipe and multi-tube hairpin exchangers.
- Tube Layout optimisation.
- Graphical input to customise Tube Layout.
- Plain or low fin tubes, longitudinally finned tubes.
- Low fin tube database.
- Single and double segmental baffles, no tubes in window, rod baffles and unbaffled units.
- Vibration analysis; flow stability checks for thermosyphons.
- Input in SI, metric or US customary (British) units.
- Versatile interface between UniSim® STE and the UniSim® Design process simulator.
- Import from UniSim® Design or other process simulators.
- Setting Plan and TEMA sheet output; optional TEMA style input.
- Budget costing package - customise to your own labour and materials costs.
- Specify f and j factors for enhanced tubeside or shellside surfaces.

1.4 UniSim® CFE

Air-cooled Heat Exchangers (and other Crossflow Exchangers)

You can use UniSim® CFE to model a wide range of equipment in which air or gas flows over tube bundles; including heat recovery tube banks, economisers, air-conditioning units, wet air dehumidification, refrigeration coils and intercoolers.

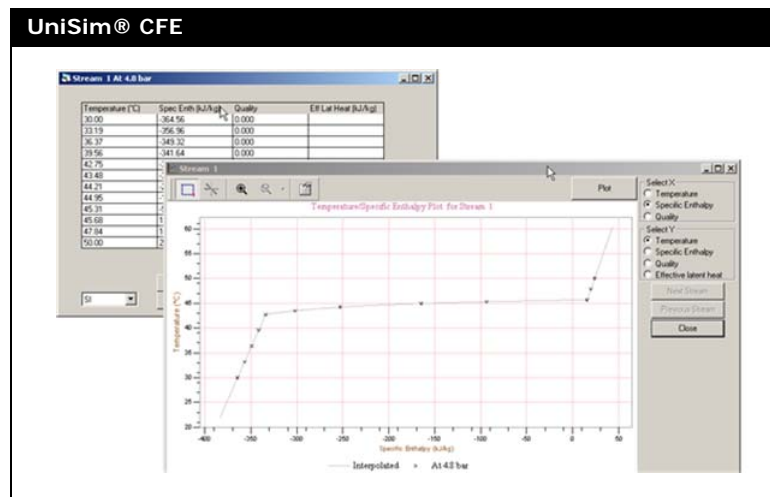

Functionality

- **SIMULATION**
- **DESIGN**
- **CHECKING**

Simulation is an extended form, for outlet conditions or flowrate, as well as special options for 'fans-off' and evaluating tubeside fouling. Design is an integrated graphical process aimed at establishing the overall size and configuration of process air-cooled heat exchangers. The checking option calculates a heat transfer area ratio (actual/required) to indicate whether a given exchanger will meet a required duty.

Technical Summary

- Tube/Types - Plain; high fin; low fin; serrated fin; studs; tube-in-plate. Up to 4 different types in each bundle.
- High-fin Tubes - Integral; G; L; extruded or bi-metallic, shoulder grooved.
- Stud Types - Circular; rectangular; elliptical; lenticular; chamfered.
- Header Types - Box; plug; cover plate; D-header; manifold; U-tube.
- Up to 50 passes in simple and complex arrangements.
- Graphical interface to specify complex pass arrangements.
- 2 to 100 rows with multiple bundles per bay and multiple bays per unit.
- Forced draught; induced draught; no fans.
- Single-phase heating or cooling; boiling or condensing on the process side.
- Tube-side Enhancements - Specified on a pass basis; twisted tapes; enhancement factors; j and f input.
- X-side can be dry air, wet air (dehumidifying) or multi-component gas mixture.
- Inlet distributions of X-side temperature and velocity can be specified.
- Performance of proprietary surfaces can be used and stored in a databank.
- Radiation heat transfer can be taken into account.
- Special interfaces to CF-P20 fan selection software of Ventilatoren Sirocco Howden BV (VSH).
- Standard fouling resistance or: tubeside fouling as a function of velocity; temperature; quality; phase or length.
- X-side fouling as a function of row.
- A and V-frame air cooled condensers.
- Non-circular tubes (oval, flat).
- Fan inlet types.
- X-side enhancements.
- Input in SI, metric or US customary (British) units.
- Import from UniSim® Design or other process simulators.

1.5 UniSim® PFE

Plate-fin Heat Exchangers

The UniSim® PFE program is for the design and performance simulation of brazed aluminium plate-fin heat exchangers of the type used in cryogenic air separation plant, natural gas processing, liquefied natural gas and petrochemical production. Exchangers can be modelled with up to 15 process streams in co- or counter-current flow and any complexity of exchanger inlet and outlet geometry. Single units and multiple blocks in series or parallel with vertical or horizontal orientations, can be modelled. Thermosyphon reboiler calculations can be performed for either internal or external types. The programs can also be used for plate-fin heat exchangers in stainless steel or titanium.

Extensive pressure drop calculations are available for common layouts of inlet and outlet distributors and checks are made for possible flow distribution problems.

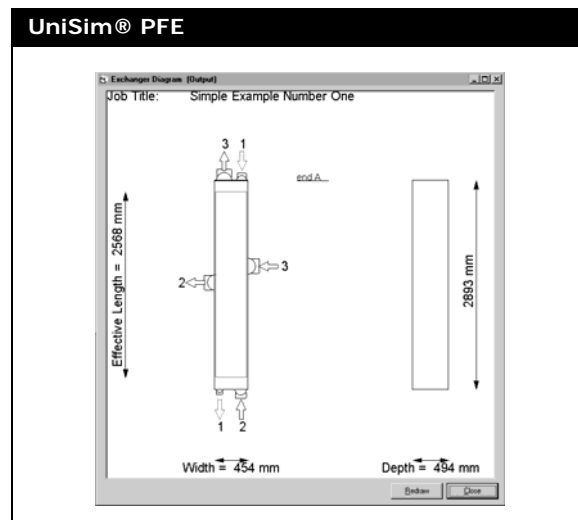

Functionality

- DESIGN
- CHECKING
- SIMULATION
- THERMOSYPHON

Simulation can be on a stream by stream or layer by layer basis.

Technical Summary

- 'Basic' input option for new users.
- Exchanger diagram to aid input review.
- Up to 15 process streams in co-current, counter-current or crossflow with any complexity of exchanger inlet and outlet geometry.
- Single phase, boiling and condensing (any combination).
- Vertical or horizontal units.
- Specify/evaluate stacking pattern.
- Exchanger, distributor, header and nozzle pressure drop calculations.
- Multiple exchangers in parallel.
- Longitudinal thermal conduction effects evaluated.
- Fin performance correlations included.
- Accepts SI, metric and US customary (British) units.
- Import from UniSim® Design or other process simulators.

1.6 UniSim® FPH

Fired Heaters

The UniSim® FPH program is for the simulation of oil and gas fired heaters of the type used in process industry applications such as hot oil heaters, refinery and reactor charge heaters, steam reformers and heat recovery duties.

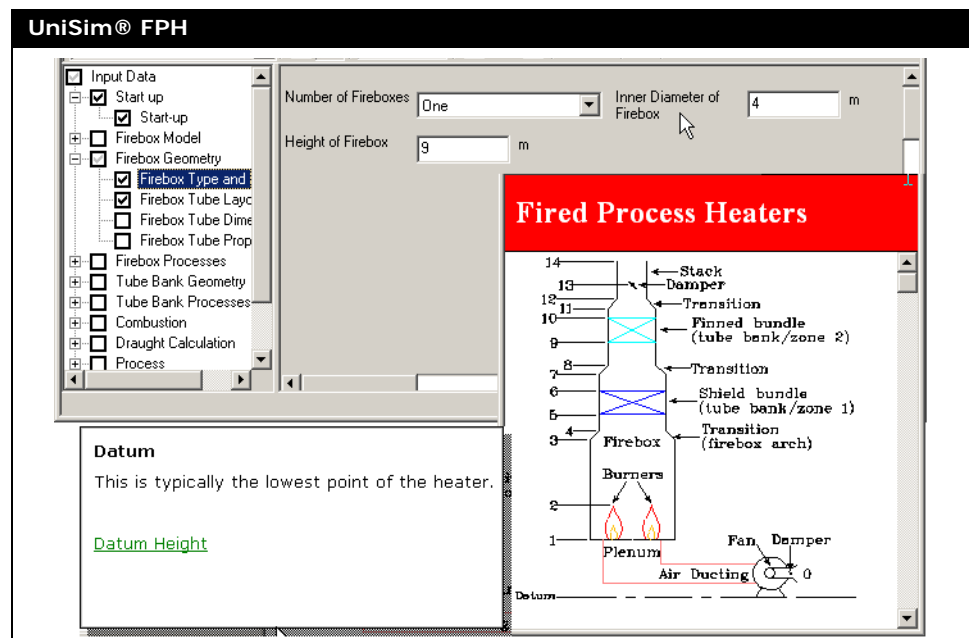

Functionality

- **SIMULATION**
- **FUEL FLOWRATE (for a specified duty)**

Technical Summary

- Extensive help and firebox and tube bank diagrams to aid input.
- Firebox radiation modelling by well-stirred method or one-dimensional zone method (long furnace model).
- Up to ten process streams which may pass through different parts of the heater.
- Process fluid flow co- or counter to the combustion product gases.
- Single phase and boiling process streams.
- Multiple paths and passes in firebox and convection section.
- Gas or oil fired burners.
- Cylindrical fireboxes containing vertical hairpin tubes or a refractory backed helical coil.
- Cabin fireboxes with vertical or horizontal tubes which may be wall mounted or centrally mounted (in single or double rows) with firing on both sides.
- Single or twin cabin fireboxes.
- Up to nine convection section tube banks containing plain tubes or extended surfaces (fins or studs).
- Radiative heat transfer in the tube banks.
- 'Open' or 'recirculating' flue systems of constant or tapered cross section, or contain two sections of different diameter.
- The firebox or convection section can be modelled alone.
- Accepts SI, metric and US customary (British) units for data input and output.
- Import from UniSim® Design or other process simulators.

1.7 UniSim® PHE

Plate and Frame Heat Exchangers

The UniSim® PHE program is a single solution for the design, checking (rating) and performance simulation of plate heat exchangers, either gasketed plate and frame or brazed plate, of the type used for general heating and cooling duties, including vaporisation and condensation.

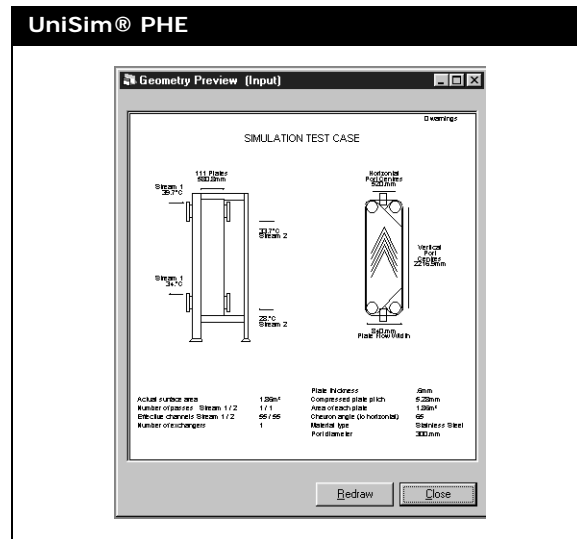

Functionality

- DESIGN
- CHECKING
- SIMULATION

Design can either use a specified plate geometry and type, or select from a range of 'typical' plates.

Technical Summary

UniSim® PHE can model:

- Single or multipass exchangers (up to 5 passes) with either co- or counter-current flow. Having one stream single pass and the other multipass is also permitted.
- DESIGN calculations use a mean coefficient and temperature difference approach, within an iteration to select the number of passes and channels per pass, to meet the constraints on heat load, pressure drop, flow velocity and port pressure loss.

- DESIGN calculations select from a set of 120 plate sizes, which are not specific to any particular manufacturer, but are 'typical' of what may be available. Plate geometry can be specified for other calculation types. Iteration takes place over four different chevron angles, and if appropriate over a range of plate sizes to establish possible designs. Chevron angles can range from 30 to 65 degrees (angle to horizontal).
- EXTEND calculations are a special form of DESIGN, in which you specify the plate to be used and the required number of plates is determined.
- In SIMULATION and CHECKING modes, there can be a different number of channels in each pass. Calculations are performed on a more detailed basis, with each pass in the exchanger being modeled separately, with 25 calculation points per pass. Full allowance can thus be made for non-linear temperature profiles, and for variation in heat transfer coefficients and pressure gradients. The effects of any flow maldistribution among the plates are also handled.
- Streams may be single phase, or boiling or condensing. Non-Newtonian fluids are also handled.
- Accepts SI, metric and US customary (British) units for data input and output.

1.8 UniSim® FWH

Feedwater Heaters

UniSim® FWH is a specialist program for power plant feedwater heaters, making allowance for the particular shell and tube geometry used for desuperheating and condensing the steam heat source.

UniSim® FWH

Bundle Heater Orientation

You may specify one of the following heater orientations;

- Horizontal (DEFAULT)
- Vertical head down
- Vertical head up

Diagrams of various exchanger with various orientations are shown below.

D = Desuperheating zone
S = Subcooling zone

Functionality

- SIMULATION
- CHECKING

Technical Summary

- Handles one-, two- and three-zone heaters of the shell and tube type.
- Drain cooling section can be of either the full-pass or split-pass type.
- Horizontal or vertical orientation.
- 1 or 2 tube passes.
- Rear head - U-tube and channel.
- Counter-current or split flow desuperheating section.
- Plain tube type.
- Triangular, rotated triangular, square and rotated square tube layouts.
- Single or double segmental plate type baffles. For other baffle types details of heat transfer and pressure drop correlations must be supplied. Condensing zone - baffles are considered to be full circle, such that the predominant flow direction is crossflow.

- UniSim® FWH accommodates flash stream and/or drains supplied separately to the heater shell, in addition to the extraction steam from the turbine.
- Steam and water properties are calculated internally.
- The effect of special baffle types on heat transfer and pressure drop can be specified by user correlations.
- Flow induced vibration check.
- Checks made for wet-wall conditions occurring in the desuperheating zone and for flashing of condensate in the drain-cooling zone.
- Condensate re-heat calculation: allowance can be made for heat transfer through the drain-cooler shroud from the steam in the condensing zone to the condensate in the drain-cooler.

1.9 UniSim® PPL

For Unbranched Pipelines

UniSim® PPL is for simulation of pipelines. Allowance is made for bends, fittings and changes of section, single or two-phase flow, and single or multiple chokes.

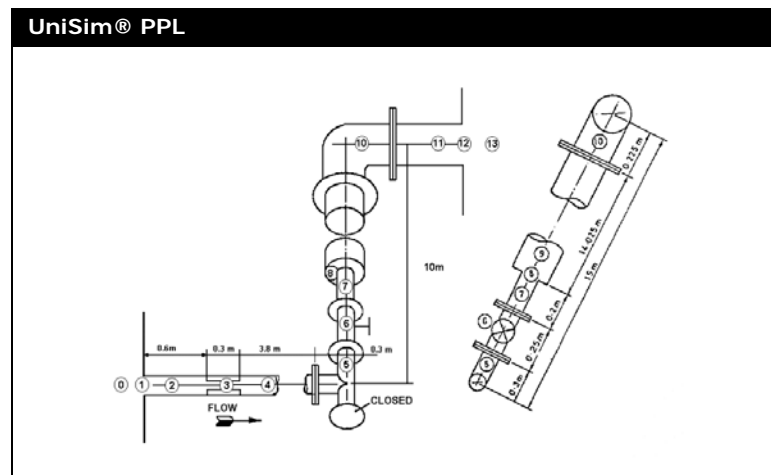

Functionality

• SIMULATION

The program relates the inlet pressure, outlet pressure and flowrate in a pipeline. Given any two of these parameters the program calculates the third.

Technical Summary

UniSim® PPL can determine:

- The pressure drop for given mass flowrate and pipeline geometry.
- The mass flowrate corresponding to a supplied pressure drop and pipeline geometry.
- The diameter factor to size a pipeline for a given pressure drop and mass flowrate.
- The critical mass flowrate for a given pressure drop and pipeline geometry for high velocity flow.
- Perform a 'multiple choke' calculation (for example, safety valves and relief systems).
- Accepts SI, metric and US customary (British) units for data input and output.

UniSim® PPL supports import from UniSim® Design or other process simulators.

1.10 Documentation for UniSim® Heat Exchanger Programs

This UniSim Heat Exchanger User Guide provides basic information on UniSim Heat Exchanger programs and how to install them. More complete information is available on the Software media and in the Help Text within each program.

On the Software media you will find:

- UniSim Heat Exchanger User Guide
- Getting Started Guide for each program
- Reference Guide for each program, including a set of worked examples

If there are significant differences, they will be reported in the **Read Me**. You can access this from the **UniSim Heat Exchanger Program Selection** screen, when you use the Software media.

1.11 Technical Support

Technical support is available by phone (1-403-509-1379 or 1-866-392-8748 toll free in North America), fax (1-403-216-2801).

E-mail support for customers with a current support contract for their product is available.

Honeywell	Email Address
Global	unisim.support@honeywell.com
North America	unisim.support@honeywell.com
Latin America	unisim.support.lar@honeywell.com
Europe, Middle East, Africa	unisim.support.emea@honeywell.com
Asia Pacific	unisim.support.ap@honeywell.com

On-line support can be accessed via <http://www.honeywell.com/ps>.

When contacting us via email or phone, please include in your message:

Your full name, company, phone and fax numbers.

The software version you are using (shown in the Help menu, About UniSim...).

A detailed description of the problem (attach a simulation case if possible).

